VIMAR

EQUIPOS



MAX2

PREPODADORA PROFESIONAL
RECORTADORA DE FALDAS

MAX2

PREPODADORA PROFESIONAL RECORTADORA DE FALDAS

EQUIPAMIENTO DE SERIE

- Recortadora de faldas de árboles
- Módulo de desplazamiento de 500 mm o 700 mm
- Elevación hidráulica +300 mm
- Kit pendular para control inclinación
- Enganche frontal placa+ contraplaca
- Central hidráulica trasera 70 L enganche CAT II
- Mando eléctrico 2 motores y 4 cilindros
- Plásticos técnicos autolubricados en los movimientos relativos entre componentes
- Protecciones para evitar accidentes según normativa CE

Recortadora de faldas de árboles para cultivos de arbolado en súper-intensivo montada en portainplementos para la parte frontal del tractor con central hidráulica trasera.

MODELO	PDFKIT000	PDFKIT001
A- (MIN) mm	2104	2804
B- (MAX) mm	2804	3004
Peso	615 Kg	625 Kg







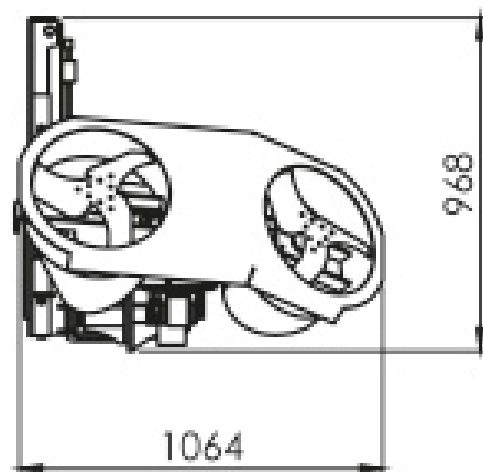
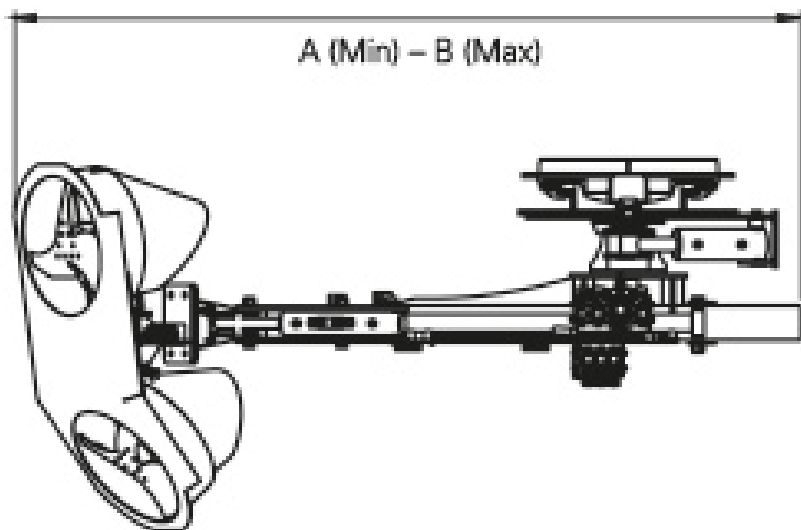

Joystick

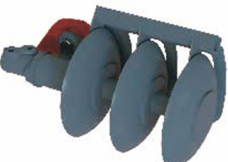

Central hidráulica incluida
VM150



Las imágenes y las características técnicas son meramente indicativas y no vinculantes.
Cualquier modificación de tipo técnico o comercial se realizará sin obligación alguna de aviso previo.

ACCESORIOS	REF.	L (MM)	
	IAC139DV	370 D/R	
	IAC139KV	2 x 370	
	IAC141DV	500 D/R	
	IAC141KV	2 x 500	
	IAC143DV	620 D/R	
	IAC143KV	2 x 620	
	IAC133DV	D/R	
	IAC133KV	2 uds	
	IAC122DV	350 D/R	
	IAC122KV	2 x 350	
	IAC079DV	450 D/R	
	IAC079KV	2 x 450	
	IAC145DV	600 D/R	
	IAC145KV	2 x 600	
	IAC131DV	350 D/R	
	IAC131KV	2 x 350	
	IAC124DV	450 D/R	
	IAC124KV	2 x 450	
	IAC195DV-500	CUCHILLA L=500mm (D/R)	Ø FRESA Ø350 mm
	IAC195KV-500	2 x L=500 mm	2 x Ø350
	IAC195DV-620	L=620mm (D/R)	Ø350 mm
	IAC195KV-620	2 x L=620 mm	2 x Ø350
	IAC137DV	D/R	
	IAC137KV	2 uds	
	PAC084V	Ø800 Disco desbrozador fijo (sin palpador) para trabajar junto al disco estándar con palpador	

ACCESORIOS REF. L (MM)

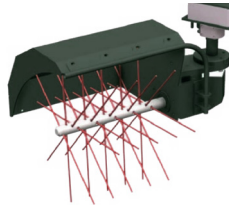

IAC222DV 500
IAC222KV 2 x 500



IAC135DV 600 mm D/R

IAC135KV 2 uds x 600 mm



IDA246DV 2 DISCOS D
IDA246KV 2 DISCOS X 2 UDS









IAC071V 2 DISCOS D
IAC058V 3 DISCOS D
IAC069V 2 DISCOS
 (2 UDS)
IAC070V 3 DISCOS (2UDS)



IAC186V Ø540MM 50 Kg
IAC187V Ø700MM 57 Kg

OLIV-MAX2 FRONTAL - MODELOS

REF.	 Ø (mm)	 Min-Max (mm)	 OIL Lt / min
PDFKIT072	800	1750-2800	60
PDFKIT073	1000	1850-3000	60
PDFKIT074	800	2050-3000	60
PDFKIT075	1000	2150-3200	60

REF.	 Ø (mm)	 Min-Max (mm)	 OIL Lt / min
PDFKIT076	800	1750-2800	60
PDFKIT077	1000	1850-3000	60
PDFKIT078	800	2050-3000	60
PDFKIT079	1000	2150-3200	60

